

# FIELDKING

Tandem Disc Harrow  
(All Series)



➤ [Operator Manual](#) ➤ [Service Manual](#) ➤ [Part Catalogue](#)

## CONGRATULATIONS!

You have invested in one of the best implements of its type in the market today.

The care you give your "FIELDKING" implement will greatly determine your satisfaction with its performance and its service life. A careful study of this manual will give you a thorough understanding of your new implement before operating.

If your manual is lost or destroyed, "FIELDKING" will be glad to provide you a new copy. Visit to nearest dealership & get a copy. Most of our manuals can also be downloaded from our website at [www.fieldking.com](http://www.fieldking.com).

As an authorized "FIELDKING" dealer, we stock genuine "FIELDKING" parts which are manufactured with the same precision and skill as our original equipment. Our trained service persons are well informed on methods required to service "FIELDKING" equipments and are ready to help you.

Should you require additional information or assistance, please contact us.

YOUR AUTHORIZED

FIELDKING DEALER

BECAUSE "FIELDKING" MAINTAINS AN ONGOING PROGRAMME OF PRODUCT IMPROVEMENT, WE RESERVE THE RIGHT TO MAKE IMPROVEMENTS IN DESIGN OR CHANGE IN SPECIFICATION WITHOUT INCURRING ANY OBLIGATION TO INSTALL THEM ON UNITS PREVIOUSLY SOLD. BECAUSE OF THE POSSIBILITY THAT SOME PHOTOGRAPHS IN THIS MANUAL WERE TAKEN OF PROTOTYPE MODELS, PRODUCTION MODELS MAY VARY IN SOME DETAIL. IN ADDITION, SOME PHOTOGRAPHS MAY SHOW SHIELDS REMOVED FOR THE PURPOSE OF CLARITY. NEVER OPERATE THIS IMPLEMENT WITHOUT ALL SHIELDS IN PLACE.

## TO THE PURCHASER

This manual contains valuable information about your new "FIELDKING" tandem disc harrow. It has been carefully prepared to give you helpful suggestions for operating, adjusting, servicing and ordering spare parts.

Keep this manual in a convenient place for quick and easy reference. Study it carefully. You have purchased a dependable and sturdy tandem disc harrow but only by proper care and operation you can expect to receive the service and long life designed and built into it.

Sometime in the future your tandem disc harrow may need new parts to replace which are worn out or broken out. If so, go to your dealer and provide him equipment's detail like model and part number.

### CUSTOMER INFORMATION

Name \_\_\_\_\_

Purchased From \_\_\_\_\_

Date of Purchase \_\_\_\_\_

Model No. \_\_\_\_\_

Serial No. \_\_\_\_\_

## PURCHASER / OPERATOR'S RESPONSIBILITY

1. Read and understand the information contained in this manual.
2. Operate, lubricate, assemble and maintain the equipment in accordance with all instructions and safety procedures in this manual.
3. Inspect the equipment and replace or repair any parts that are damaged or worn out which under continued operation would cause damage, wear to other parts, or cause a safety hazard.
4. Return the equipment or parts to the authorized "FIELDKING" dealer, from where it was purchased, for service or replacement of defective parts that are covered by warranty. (The "FIELDKING" Factory may inspect equipment or parts before warranty claims are honored.)
5. All costs incurred by the dealer for traveling to or transporting the equipment for warranty inspection and claims will be borne by the customer.

## INDEX

### 1. TECHNICAL DATA

- 1.1 Introduction
- 1.2 Warranty
- 1.3 When the warranty becomes void
- 1.4 Warning

### 2. USAGE INSTRUCTIONS

- 2.1 Before use & adjustments
- 2.2 Attaching harrow to the tractor
- 2.3 Warning for driver
- 2.4 Safety

### 3. MAINTENANCE

- 3.1 Maintenance Instructions
- 3.2 Storage of machine after work
- 3.3 Lubrication
- 3.4 Instruction for driver

### 4. OPERATIONAL GUIDELINES FOR HARROW

### 5. TROUBLE SHOOTING CHART

## 1. TECHNICAL DATA

### 1.1 INTRODUCTION

This handbook contains the use and maintenance instructions with a list of the spare parts of the Tandem Disc Harrow.

This Disc harrow is equipped with light duty & heavy duty box frame specially designed for harrowing / land preparation of rough soil (Secondary finer operation).

Regular and satisfactory operation together with economic and long lasting use of the implement depends on the compliance with instructions given in this handbook.

Compliance with the instructions in this handbook is also important since Manufacturer declines all and every responsibility for damage to persons or property caused by negligence and failure to comply with these instructions.

### 1.2 WARRANTY

When the machine is delivered, check that it has not been subjected to damage during transport and that the accessories are in a perfect condition and complete.

Any claims following the receipt of damaged goods shall be presented in writing within 8 days from the receipt of the goods.

The purchaser may only make the claims under guarantee when he has complied with the warranty conditions in the supply contract.

### 1.3 WHEN THE WARRANTY BECOMES VOID

Besides the cases specified in the supply agreement, the guarantee shall in any case become void.

1. When the implement has been used beyond the specified power limit like (Tractor Horse Power)
2. When repairs made by the customer without authorization from the manufacturer or owing to installation of spurious spare parts, the machine is subjected to variations and the damage can be ascribed to these variations.
3. When the user has failed to comply with the instructions in this handbook.
4. If the implement is used in very hard/stony soil no warranty of discs will be given.
5. No warranty will be given if the service and greasing is not done on time.

### 1.4 WARNING

1. Thoroughly read the instruction manual before proceeding with the various operations.
2. Maintain the harrow as per the instructions of this handbook to be entitled for warranty.

## 2. USAGE INSTRUCTIONS

### 2.1 BEFORE USE & ADJUSTMENTS

1. Before mounting of disc harrow make sure that all nuts & bolts are properly secured.
2. Also determine soil and trash conditions of the field and make the preliminary adjustments.

#### a) Disc gang angle & gang angle lateral adjustment

##### i) Disc Angling

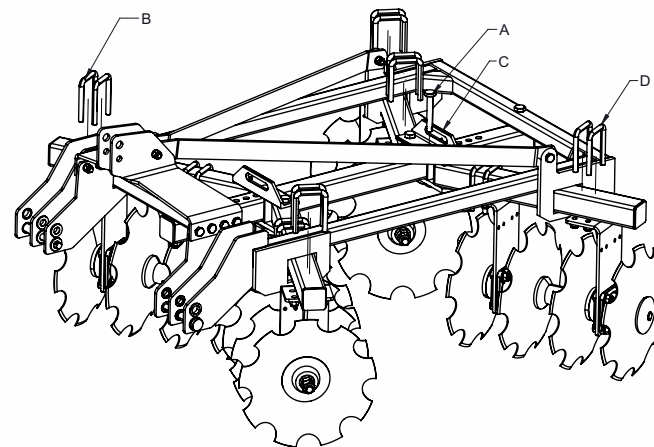

**NOTE:** The more angle you have on the disc, the more aggressive the cut will be and the more horsepower will be required to pull your harrow and for a better ground finish, the rear gang angle should be lesser than the front gangs.

- The disc harrow is design with handles (C) to make disc gang angle adjustment easy. Adjust disc gang as follow:
- Remove pin (A) and hair linch pin (F).Slide handle (C) to desired position and replace pin.

##### ii) Disc gang lateral adjustment:-

- Gang angle (Angle between two gangs) ranges between 00 to 66°. The angle can be increased for better penetration in dry soil while it should be reduced to avoid clogging in wet soil.

**NOTE:** The rear discs should be centered between the front discs for optimum performance.

##### b) Disc harrow leveling

The truest way to level your disc from front to rear is to observe behind the center of disc harrow. In most soil condition, a slight ridge in the centre is actually a level operation. More air pockets will form where soil is thrown against each other, causing a small ridge to form that will disappear after a soaking rain.

- If harrow is leaving a significant ridge in the centre, raise disc rear gangs by shortening the centre 3- point link.
- If harrow is leaving a furrow (valley) in the centre, lower rear disc gang by lengthening the centre 3- point link.
- See also troubleshooting chart for helpful solution to leveling the disc harrow.

### c) Scrapper adjustment

The scrapper can be adjusted by loosening the bolts.

### d) Disc harrow penetration

Factors affecting disc harrow penetration are:-

- Angle of the gang
- Weight of the harrow
- Disc diameter
- Disc sharpness
- (Blunt disc increases the draft considerably, check the disc sharpness)
- Angle of hitch

## 2.2 ATTACHING THE HARROW TO THE TRACTOR

1. Place the harrow duly leveled on the flat piece of land.
2. Reverse the tractor to the harrow.
3. Attach the 3 point linkage to the harrow.

## 2.3 WARNING FOR THE DRIVER

1. Before harrowing check all nuts & bolts of the disc harrow.
2. Be vigilant about the tree roots and stones. Don't harrow on stony soil.
3. Tractor should be in first high or fourth low gear.
4. Don't allow anyone to come across the harrow.

## 2.4 SAFETY

Understanding the machine safety labels



**Safety-Alert Symbol**

The machine safety labels shown in this section are placed in important areas on your machine to draw attention to potential safety hazards

On your machine the words DANGER, WARNING, and CAUTION are used with this safety-alert symbol. DANGER identifies the most serious hazards.

The operator's manual also explains any potential safety hazards whenever necessary.

- Before harrowing with disc harrow take care that nobody stands near it.



**In order to protect yourself always wear adequate clothes and shoes during the operations.**



**Never allow riders on the tractor or implement unless an additional seat is available.**



**Be careful when moving around steep gradient to avoid sharp turn.**

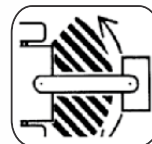

**Never transport the implement on rough roads during the night. When operating, avoid sharp turns that may cause tractor colliding with the implement.**

## 3. MAINTENANCE

### 3.1 MAINTENANCE INSTRUCTIONS

If you work the tandem disc harrow on stony land then maintenance also increases.

1. If the soil has entered the grease nipple, then change the nipple.
2. If disc harrow is new after initial working of first two hours, tighten all nuts & bolts.
3. After every fifty hours grease all greasing points with grease gun and tighten all nuts & bolts.
4. After fifty hours, open the Bearing hub/Bearing spool of tandem disc harrow & cleanse with diesel oil & pump in new grease.

### 3.2 STORAGE OF MACHINE AFTER WORK

1. Wash the tandem disc harrow after work.
2. Replace the worn out nuts & bolts.
3. If tandem disc harrow has to remain unused for long time then clean it & apply a layer of used oil for rust prevention.

These steps will enhance the life of your disc harrow.

### 3.3 LUBRICATION

1. Please take care that the high quality grease is used in the greasing points.
2. Please take care that the hydraulic oil quality grease is used in the greasing points.



Be careful with the environment. Do not spill combustible oil, battery and filter residues in the soil. These trashes in contact with the soil reach sub layer which directly damage the environment. Look for the information to recycle or re-use them.

### 3.4 INSTRUCTIONS FOR DRIVER

1. In case of scrapper touching the discs, loosen the scrapper bolt and readjusts the scrapper.
2. Never reverse the tractor when the harrow is engaged in the soil.
3. Never turn the tractor to the right or left when the harrow is engaged in the soil.
4. Properly fit the three point linkage as mentioned above & lock with lynch pin.
5. To get good results from the harrow, disc should be replaced when its diameter is reduced by 5" from its original size.
6. When Tandem Disc Harrow is ready for use don't stand between harrow & the tractor.

### 4. OPERATIONAL GUIDELINES FOR HARROW

1. Adding of wheel weights/water ballasting or combination of both is recommended when excessive rear wheel slippage is experienced.
2. Always set hydraulic levers correctly for draft and position control operation.
3. Lift the harrow on turning for effective independent breaking of soil.

### Precautions during transportation

1. Maintain the speed to avoid jumps.
2. Watch while over taking on road.
3. Always use SMV (Slow Moving Vehicles) symbols.



**Dear user!**  
**Respect the Ecology.**  
**Do not throw the trash away.**  
**This gesture helps to protect our Environment.**

## 5. TROUBLE SHOOTING CHART

SR. NO.	Problem	Possible Cause	Possible Remedy
1	Disc harrow makes a high center ridge.	Disc blades are moving too much soil to the centre.	Tilt disc harrow up at the rear by shortening the centre 3- point link.
			Decrease tractor speed.
2	Disc harrow cuts a furrow (valley) in the center.	Disc blades are moving enough soil to the center.	Increase spacing between disc gangs by moving all gang hangers on both sides away from the centre equal amounts.
			Tilt disc harrow down at the rear by lengthening the center 3-point link.
3	Disc harrow makes ridges on the out side cuts and furrows just inside the ridges.	Too much soil is thrown out by the front disc gangs.	Increase tractor speed.
			Reduce spacing between rear disc gangs by moving all gang hangers on both sides toward the center by equal amounts.
4	Disc harrow makes a furrow on the out side cuts and a ridge just inside the furrow.	Rear disc gangs are set too wide and picks up soil beyond where the front ganges throw it out.	Check front to rear disc leveling. Rise front disc gangs by lengthening the center 3-point link.
			Reduce front disc gang angle by one position.
5	Disc harrow does not pull straight and/ or shifts from side to side.	Front disc gangs run deeper than the rear disc gangs.	Reduce spacing between rear disc gangs by moving all rear gang hangers in toward the center by equal amounts.
			Raise front disc gangs by lengthening the center 3- point link.
6	Disc harrow leaves a depression in the worked soil behind tractor wheels.	Disc gangs are not centered on the frame.	Tilt disc harrow down at the rear by lengthening the center 3-point link.
			Center disc gangs on the disc harrow.
7	Disc harrow won't settle down and operate smoothly.	Disc gang angles are set too high.	Set front disc gange at the same angle.
			Set rear disc gange at the same angle.
8	Disc harrow dose not penetrate soil properly.	Tire slippage, heavy tractor, soft soil conditions.	Add duals, increase tractor speed, increasegang angle and / or increase cutting depth.
			Tilt disc harrow down at the rear by lengthening the center 3-point link.
9	Disc harrow dose not penetrate soil properly.	Disc gange angle are not set enough angle.	Set disc gang angle at the smallest angle required to do the job. Make sure front disc gange are set 3 degrees higher than the rear disc gang angle.
			Increase disc gang angles. Make sure the front disc gangs are set-3 degree more than the disc gangs.
10	Bearing problem	Making sharp turns and crossing ditches with disc harrow in the ground.	Raise disc harrow out of the ground when making sharp turns and crossing ditches. Do not cross deep ditches.
			Keep disc gang axle nut tight.
10	Bearing problem	Gang axes become loose.	Replace gange axle and damaged bearing.
			Foreign objects and/ or dirt caught between spacer and disc blades causing bearing to wobble.
			Completely disassembly disc gang components and cleane thoroughl before reassembling. Replace damage bearing.
			Remove abrasive materal right away. Replace damaged bearings.
10	Bearing problem	Abrasive material such as wire ribbing against the bearing and destroying its seals.	Always clean grease zerks before pumping grease into the bearings. Replace damaged bearing.
			Pumping grease into the bearing too fast in cold weather will pop off bearing seals.
10	Bearing problem	Contaminated bearing caused by not cleaning the grease zerks before adding grease to the bearings.	Pump grease into the bearings slower especially in cold weather. Replace all damage bearing.
			Pumping grease into the bearing too fast in cold weather will pop off bearing seals.



TANDEM DISC HARROW MEDIUM DUTY (12-DISC)

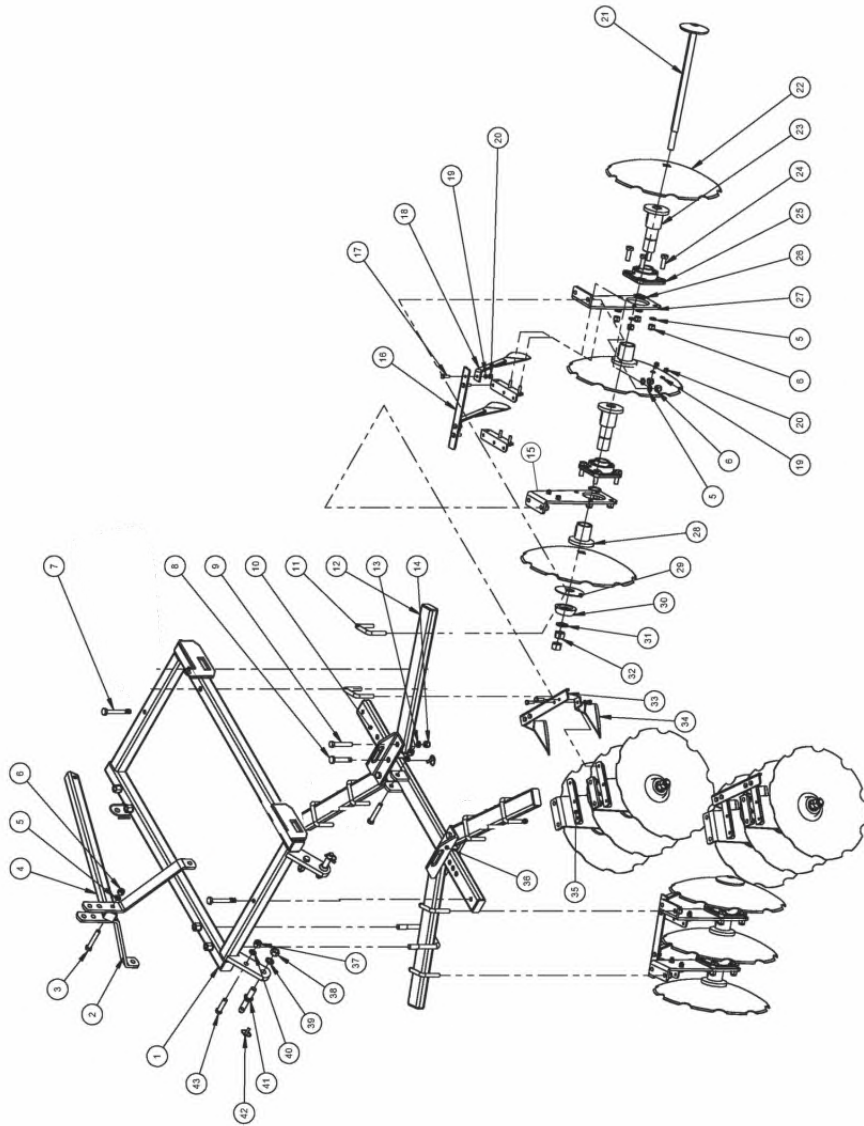

TANDEM DISC HARROW MEDIUM DUTY (12-DISC)			
Sr. No.	DESCRIPTION	PART NO.	QTY.
		93030025	12-DISC
1	MAIN FRAME ASSY. (12-DISC)	77750001	1
2	LEVER FLAT	77750006	2
3	HEX HEAD BOLT M16X105X2P	10260021	1
4	LEVER PIPE ASSY.	77770001	1
5	SPRING WASHER 16MM	10270005	56
6	NYLOCK NUT M16x2P	10280005	56
7	HEX HEAD BOLT M20x130x2.5P	10260132	2
8	PIN 19X95L	10020031	2
9	HEX HEAD BOLT M20x110x2.5P	10260431	4
10	CENTER SUPPORT ASSY.	77760001	1
11	U CLAMP 16X82X12MM	10220038	8
12	GANG PIPE ASSY.	77790001	4
13	SPRING WASHER 20MM	10270016	6
14	NYLOCK NUT M20X2.5P	10280021	6
15	LEG ASSEMBLY	77800001	8
16	SCRAPER HOLDING FLAT LEFT	77750009	2
17	HEX HEAD BOLT M10X45X1.25P	10260003	16
18	SCRAPER ASSY. LEFT	77820002	4
19	SPRING WASHER 10MM	10270002	24
20	NYLOCK NUT M10X1.5P	10280002	24
21	AXLE ROD ASSY. (3-DISC)	77780001	4
22	NOTCHED DISC 18" / 20"	10240032/10240077	12
23	BEARING SPOOL	10340014	8
24	HEX HEAD BOLT M16X50X2P	10260016	32
25	UC BEARING F210	10050031	8
26	EXTERNAL CIRCLIP DIA. 50A	10390010	8
27	LEG ASSEY.	77800001	8
28	BEARING SPOOL CAP	10180017	8
29	DISC WASHER	10270029	4
30	SMALL CHAPPEN	10360005	4
31	PLAIN WASHER 25MM	10270024	4
32	PLAIN NUT M24x3P	10280044	8
33	SCRAPER HOLDING FLAT RIGHT	77750008	2
34	SCRAPER ASSY. RIGHT	77820001	6
35	SCRAPER HOLDING ANGLE	77750007	8
36	GANG JOINT ANGLE ASSY.	77810001	2
37	NYLOCK NUT M18x1.5P	10280006	2
38	SPRING WASHER 18MM	10270006	2
39	PLAIN NUT 7/18X14UNF	10280105	2
40	PLAIN WASHER 23MM	10270041	2
41	HITCH PIN 22MM	10020121	2
42	LINCH PIN 10MM	10020022	4
43	HEX HEAD BOLT M18x65x2.5P	10260376	2

# TANDEM DISC HARROW MEDIUM DUTY (16 & 20-DISC)

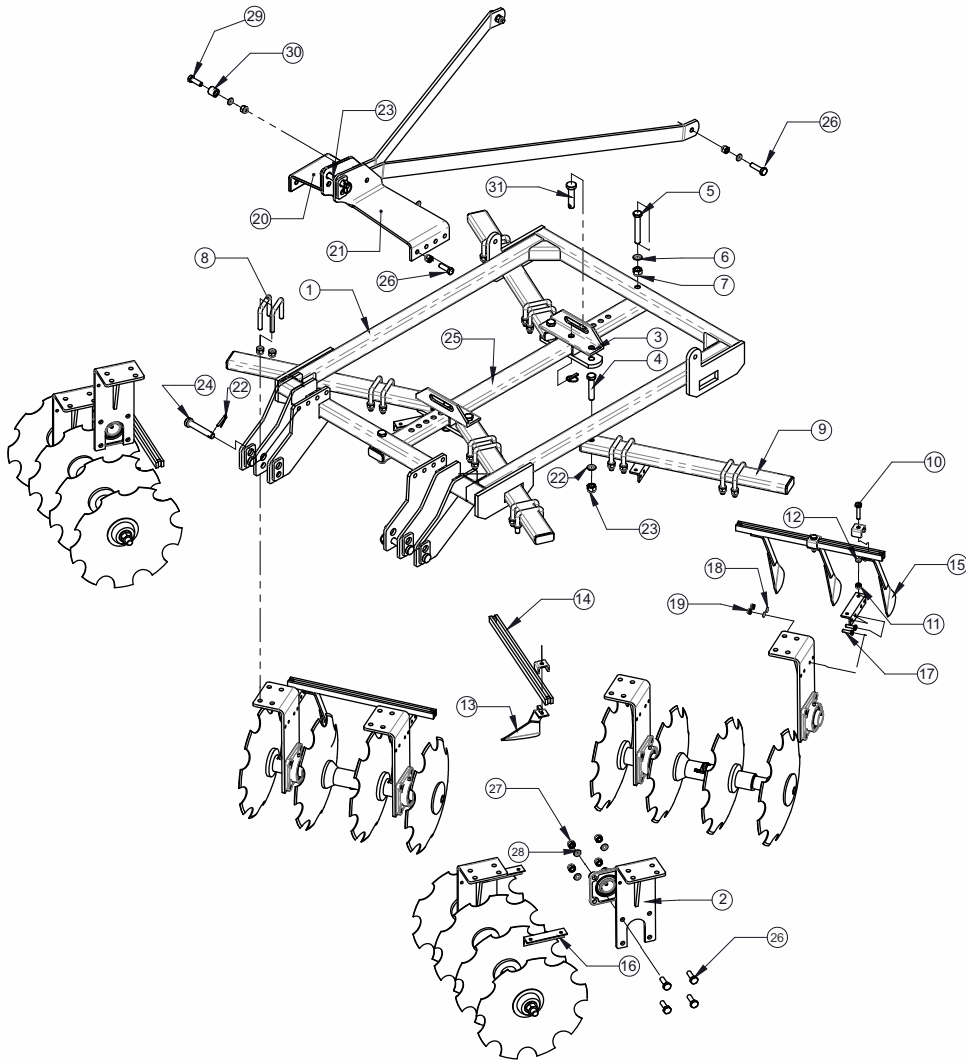

TANDEM DISC HARROW MEDIUM DUTY (16 & 20 DISC)					
Sr. No.	DESCRIPTION	PART NO.		QTY.	
		93030001	93030008	16 DISC	20 DISC
1	MAIN FRAME ASSY.	72900001		1	1
2	LEG ASSY.	77800004		8	8
3	GANG JOINT ANGLE ASSY.	77810001		1	1
4	HEX HEAD BOLT M20X110X2.5P	10260431		4	4
5	HEX HEAD BOLT M20X130X2.5P	10260132		2	2
6	SPRING WASHER 20MM	10270016		6	6
7	NYLOCK NUTM20X2.5P	10280021		6	6
8	U CLAMP SET	10220038		16	16
9	GANG PIPE ASSY.	77790003	77790005	4	4
10	HEX HEAD BOLT M12x60x1.5P	10260356		20	24
11	NYLOCK NUT M12x1.5P	10280003		20	24
12	SPRING WASHER 12MM	10270003		10	12
13	SCRAPER ASSY. LEFT	77820002		12	16
14	SCRAPER HOLDING FLAT ASSY.	77820009	77820010	4	4
15	SCRAPER ASSY. (RIGHT)	77820001		12	16
16	SCRAPER HOLDING ANGLE	78370002		8	8
17	HEX HEAD BOLT M10X35	10260353		16	16
18	SPRING WASHER 10MM	10270002		16	16
19	NYLOCK NUT M10X1.5P	10280002		16	16
20	LEVER SHEET (LHS)	77750015		1	1
21	LEVER SHEET (RHS)	77750014		1	1
22	LINCH PIN 10MM	10020022		5	5
23	PIN 19x125L	10020009		1	1
24	PIN 22x200	78370005		2	2
25	CENTER SUPPORT ASSY.	77760005		1	1
26	HEX HEAD BOLT M16x50X2P	10260358		42	42
27	NYLOCK NUTM16x2P	10280005		43	43
28	SPRING WASHER 16MM	10270005		43	43
29	HEX HEAD BOLT M16X105	10260134		1	1
30	BUSH (17x32x30)	10070008		1	1
31	PIN 19x95	10200031		2	2



**GANG AXLE ASSY. (4 & 5 DISC) MEDIUM DUTY**

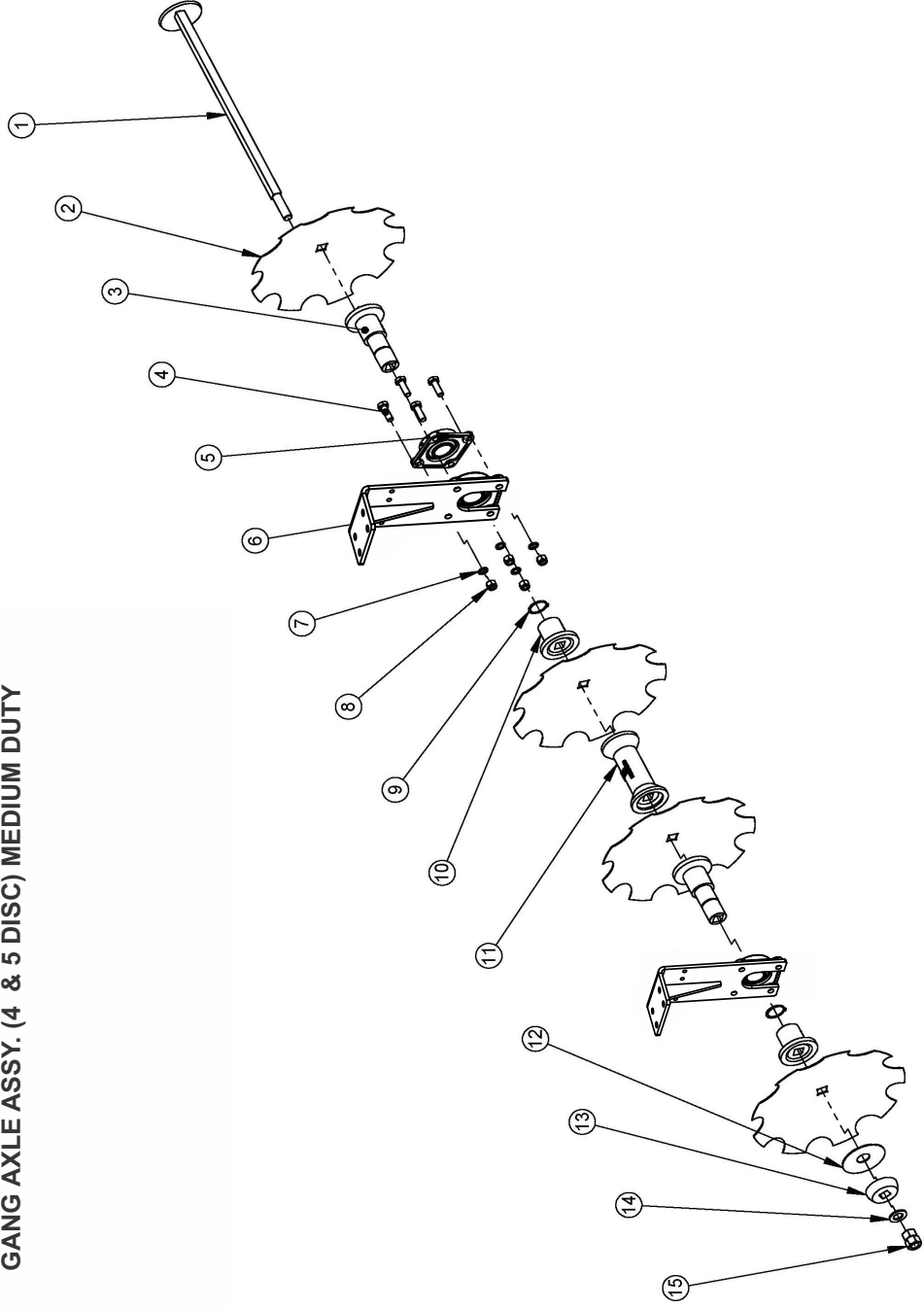

GANG AXLE ASSY. (4 & 5 DISC) MEDIUM DUTY						
Sr. No.	DESCRIPTION	PART NO.			QTY.	
		4-DISC	5-DISC	4-DISC	5-DISC	
1	AXLE ROD ASSY.	77780003	77780005		1	
2	NOTCHED DISC 18"	10240032		4		5
3	BEARING SPOOL	10340014				2
4	HEX HEAD BOLT M16x50L	10260358				8
5	UC BEARING F210	10050031				2
6	LEG ASSY.	77800004				2
7	SPRING WASHER 16MM	10270005				8
8	NYLOCK NUT M16x2P	10280005				8
9	EXTERNAL CIRCLIP 50A	10390010				2
10	BEARING SPOOL CAP	10180017				2
11	PLAIN SPOOL	10340015		1		2
12	DISC WASHER	10270029				1
13	SMALL CHAPPEN	10360005				1
14	PLAIN WASHER 25MM	10270024				1
15	HEX NUT M24X3P	10280044				2

# TANDEM DISC HARROW HEAVY DUTY 20 DISC & 24 DISC

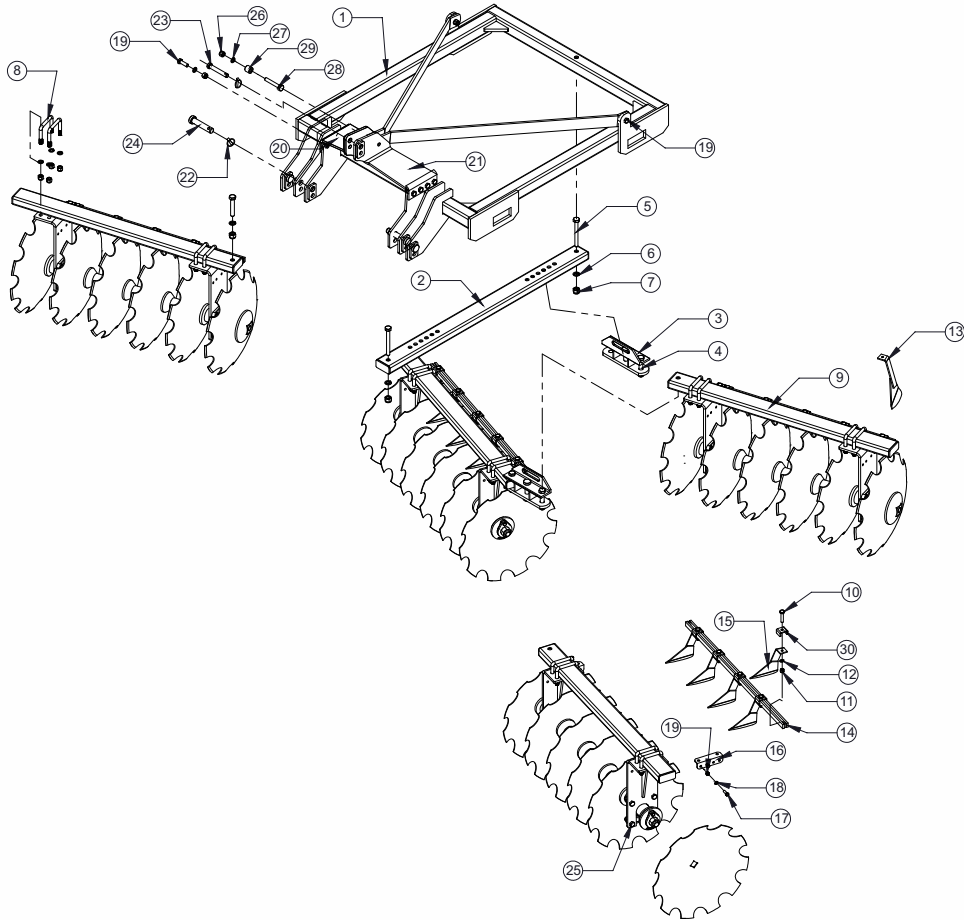

TANDEM DISC HARROW HEAVY DUTY 20 DISC & 24 DISC					
Sr. No.	DESCRIPTION	PART NO.		QTY.	
		93030028	93030023	20 DISC	24 DISC
1	MAIN FRAME ASSY.	78270001		1	1
2	CENTER SUPPORT ASSY.	78300001		1	1
3	GANG JOINT ANGLE ASSY.	78340001		2	2
4	HEX HEAD BOLT M20X110X2.5P	10260431		4	4
5	HEX HEAD BOLT M20X150X2.5P	10260035		2	2
6	SPRING WASHER 20MM	10270016		6	6
7	NYLOCK NUTM20X2.5P	10280021		6	6
8	U CLAMP SET	10220048		16	16
9	GANG PIPE ASSY.	78330001	78380001	4	4
10	HEX HEAD BOLT M12x60x1.5P	10260356		24	28
11	NYLOCK NUT M12x1.5P	10280003		24	28
12	SPRING WASHER 12MM	10270003		24	28
13	SCRAPER ASSY. LEFT	78360001		16	20
14	SCRAPER HOLDING FLAT ASSY.	77820014	77820012	4	4
15	SCRAPER ASSY. (RIGHT)	78350001		16	20
16	SCRAPER HOLDING ANGLE	78370002		8	8
17	HEX HEAD BOLT M10X35	10260353		16	16
18	SPRING WASHER 10MM	10270002		16	16
19	NYLOCK NUT M10X1.5P	10280002		16	16
20	LEVER SHEET (LHS)	78280002		1	1
21	LEVER SHEET (RHS)	78290002		1	1
22	LINCH PIN 10MM	10020022		5	5
23	PIN 19X95L	10020031		2	2
24	PIN 22x200	78370005		2	2
25	HEX HEAD BOLT M16x50X2P	10260358		32	32
26	NYLOCK NUTM16x2P	10280005		33	33
27	SPRING WASHER 16MM	10270005		33	33
28	HEX HEAD BOLT M16X105	10260134		1	1
29	BUSH (17x32x30)	10070008		1	1
30	U CLAMP	78460002		24	28

## GANG AXLE ASSY. (4 & 6 DISC) HEAVY DUTY

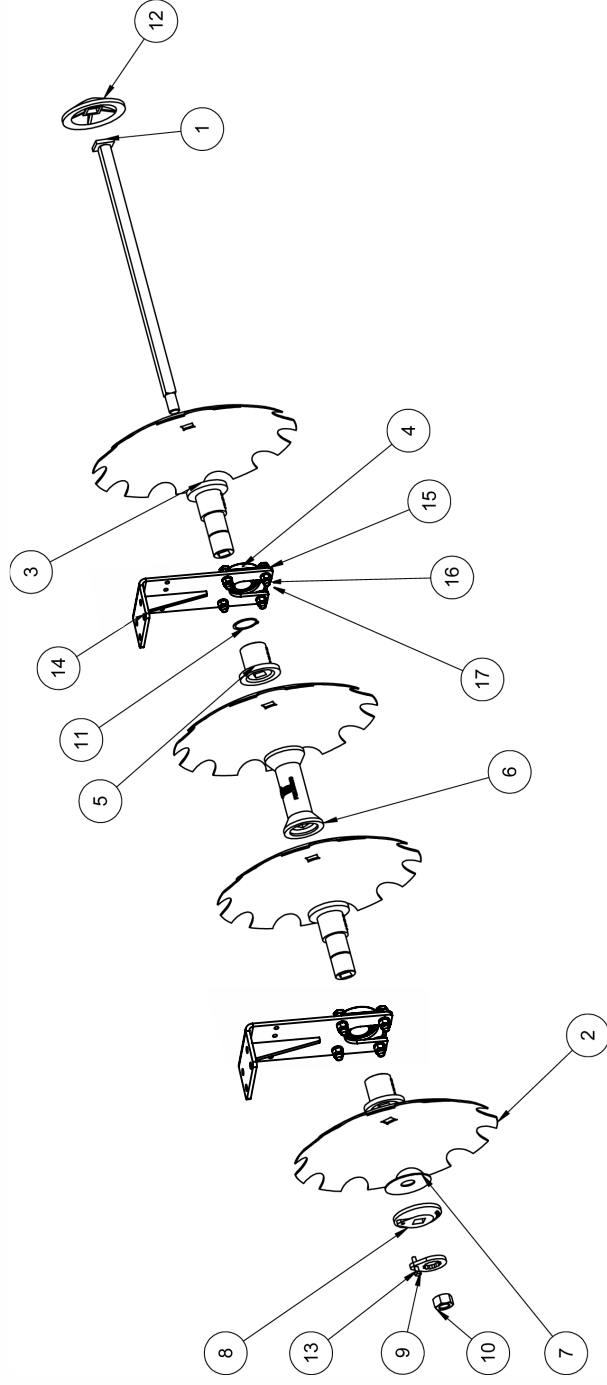

### GANG AXLE ASSY. (4 & 6 DISC) HEAVY DUTY

Sr. No.	DESCRIPTION	4-DISC	6-DISC	QTY 4-DISC	QTY 6-DISC
1	AXLE ROD ASSY.	72850002	71090001	1	1
2	NOTCHED DISC 18"	10240024		4	6
3	BEARING SPOOL	10340003		2	2
4	UC BEARING F211	10050123		2	2
5	BEARING SPOOL CAP	10180007		2	2
6	PLAIN SPOOL	10340004		1	3
7	DISC WASHER	71060002		1	1
8	CHAPPEN	10360002		1	1
9	HEX BOLT M10X45L	10260005		1	1
10	HEX NUT 28MM	76900002		1	1
11	EXTERNAL CIRCLIP A60, 2 MM THICK.	10390030		2	2
12	BIG CHAPPEN	10360003		1	1
13	GANG LOCK PLATE	71050009		1	1
14	LEG ASSY.	78310001		2	2
15	HEX HEAD BOLT M18x60L	10260082		8	8
16	NYLOCK NUT M18x2.5P	10280020		8	8
17	SPRING WASHER 18MM	10270006		8	8

TANDEM DISC HARROW LIGHT DUTY WITH 7.5" SPOOL (12 DISC)

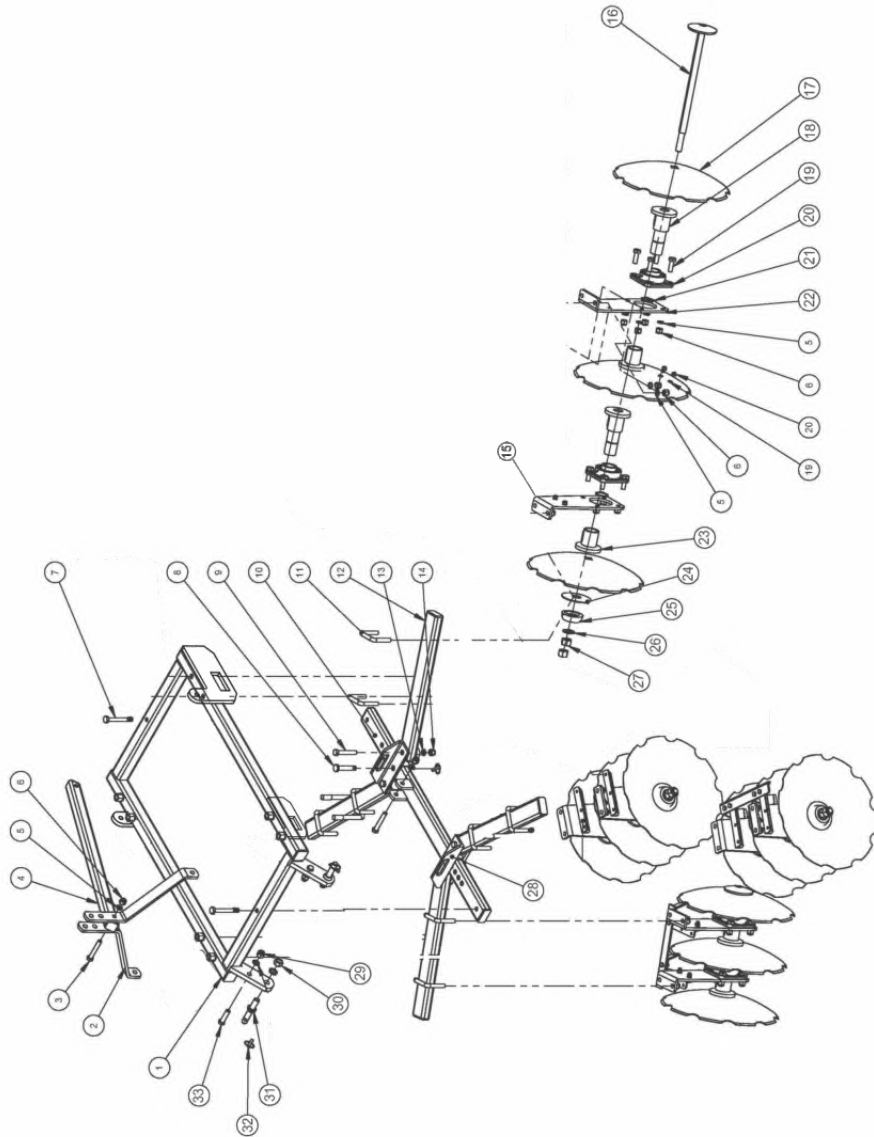

TANDEM DISC HARROW LIGHT DUTY WITH 7.5" SPOOL (12 DISC)			
Sr. No.	DESCRIPTION	PART NO.	QTY.
		93030038	12-DISC
1	MAIN FRAME ASSY. (12-DISC)	77750001	1
2	LEVER FLAT	77750006	2
3	HEX HEAD BOLT M16X150X2P	10260021	1
4	LEVER PIPE ASSY. (12-DISC)	77770001	1
5	SPRING WASHER 16MM	10270005	66
6	NYLOCK NUT M16X2P	10280005	66
7	HEX HEAD BOLT M20X130X2.5P	10260132	2
8	PIN Ø19X95L	10020031	2
9	HEX HEAD BOLT M20X110X2.5P	10260431	4
10	CENTER SUPPORT ASSY.	77760001	1
11	U-CLAMP 16X82X82MM	10220038	8
12	GANG PIPE ASSY.	77790008	4
13	SPRING WASHER 20MM	10270016	6
14	NYLOCK NUT M20X2.5P	10280021	6
15	LEG ASSEMBLY	77800001	4
16	AXLE ROD ASSY. (3-DISC)	77780007	4
17	NOTCHED DISC 18"/20"	10240032 / 10240077	12
18	BEARING SPOOL 7.5"	10340034	8
19	HEX HEAD BOLT M16X50X2P	10260016	32
20	UCF BEARING 210	10050031	8
21	EXTERNAL CIRCLIP 50A	10390010	8
22	LEG ASSY.	74360001	8
23	BEARING SPOOL CAP 7.5"	10340035	8
24	DISC WASHER	10270029	4
25	SMALL CHAPPEN	10360005	4
26	PLAIN WASHER 25MM	10270024	4
27	PLAIN NUT M24X3P	10280044	8
28	GANG JOINT ANGLE ASSY.	77810001	2
29	NYLOCK NUT M18X2.5P	10280020	2
30	SPRING WASHER 18MM	10270006	2
31	HITCH PIN 22MM	10020121	2
32	LINCH PIN 10MM	10020022	4
33	HEX HEAD BOLT M18X65X2.5P	10026376	2

**TANDEM DISC HARROW LIGHT DUTY WITH 7.5" SPOOL (16 & 20-DISC)**

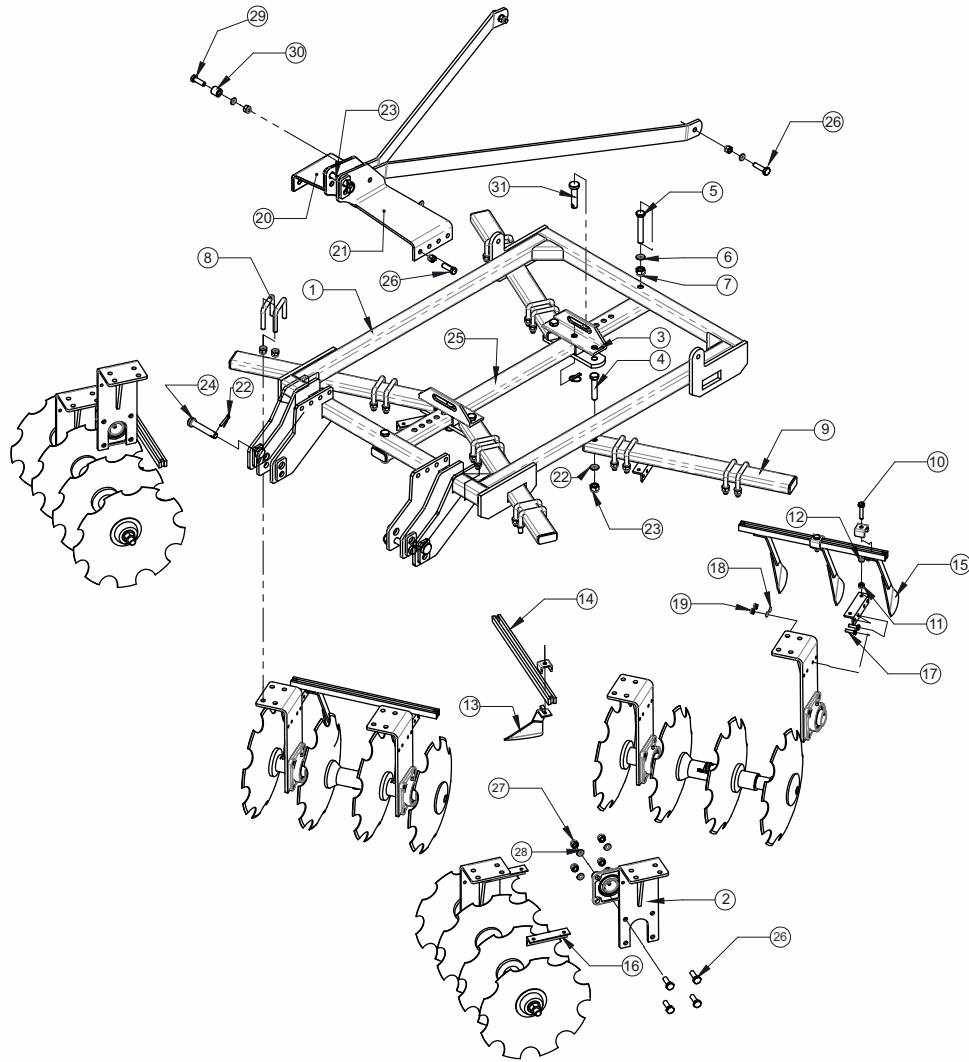

TANDEM DISC HARROW LIGHT DUTY WITH 7.5" SPOOL (16 & 20-DISC)					
Sr. No.	DESCRIPTION	PART NO.		QTY.	
		93030039	93030040	16 DISC	20 DISC
1	MAIN FRAME ASSY.	77750010		1	1
2	LEG ASSY.	77800004		8	8
3	GANG JOINT ANGLE ASSY.	77810001		1	1
4	HEX HEAD BOLT M20X110X2.5P	10260431		4	4
5	HEX HEAD BOLT M20X130X2.5P	10260132		2	2
6	SPRING WASHER 20MM	10270016		6	6
7	NYLOCK NUTM20X2.5P	10280021		6	6
8	U CLAMP SET	10220038		16	16
9	GANG PIPE ASSY.	77790009	74360001	4	4
10	HEX HEAD BOLT M12x60x1.75P	10260356		20	24
11	NYLOCK NUT M12x1.5P	10280003		20	24
12	SPRING WASHER 12MM	10270003		10	12
13	SCRAPER ASSY. LEFT	77820002		12	16
14	SCRAPER HOLDING FLAT ASSY.	77820009	77820010	4	4
15	SCRAPER ASSY. (RIGHT)	77820001		12	16
16	SCRAPER HOLDING ANGLE	78370002		8	8
17	HEX HEAD BOLT M10X35	10260353		16	16
18	SPRING WASHER 10MM	10270002		16	16
19	NYLOCK NUT M10X1.5P	10280002		16	16
20	LEVER SHEET (LHS)	77750015		1	1
21	LEVER SHEET (RHS)	77750014		1	1
22	LINCH PIN 10MM	10020022		5	5
23	PIN 19x125L	10020009		1	1
24	PIN 22x200	78370005		2	2
25	CENTER SUPPORT ASSY.	77760005		1	1
26	HEX HEAD BOLT M16x50X2P	10260358		42	42
27	NYLOCK NUTM16x2P	10280005		43	43
28	SPRING WASHER 16MM	10270005		43	43
29	HEX HEAD BOLT M16X105	10260134		1	1
30	BUSH (17x32x29)	10070005		1	1
31	PIN 19x95	10200031		2	2
32	AXLE ROD ASSY. 7.5" SPOOL	77780008	77780009	4	4

**GANG ASSEMBLY LIGHT DUTY WITH 7.5" SPOOL (4 & 5 DISC)**

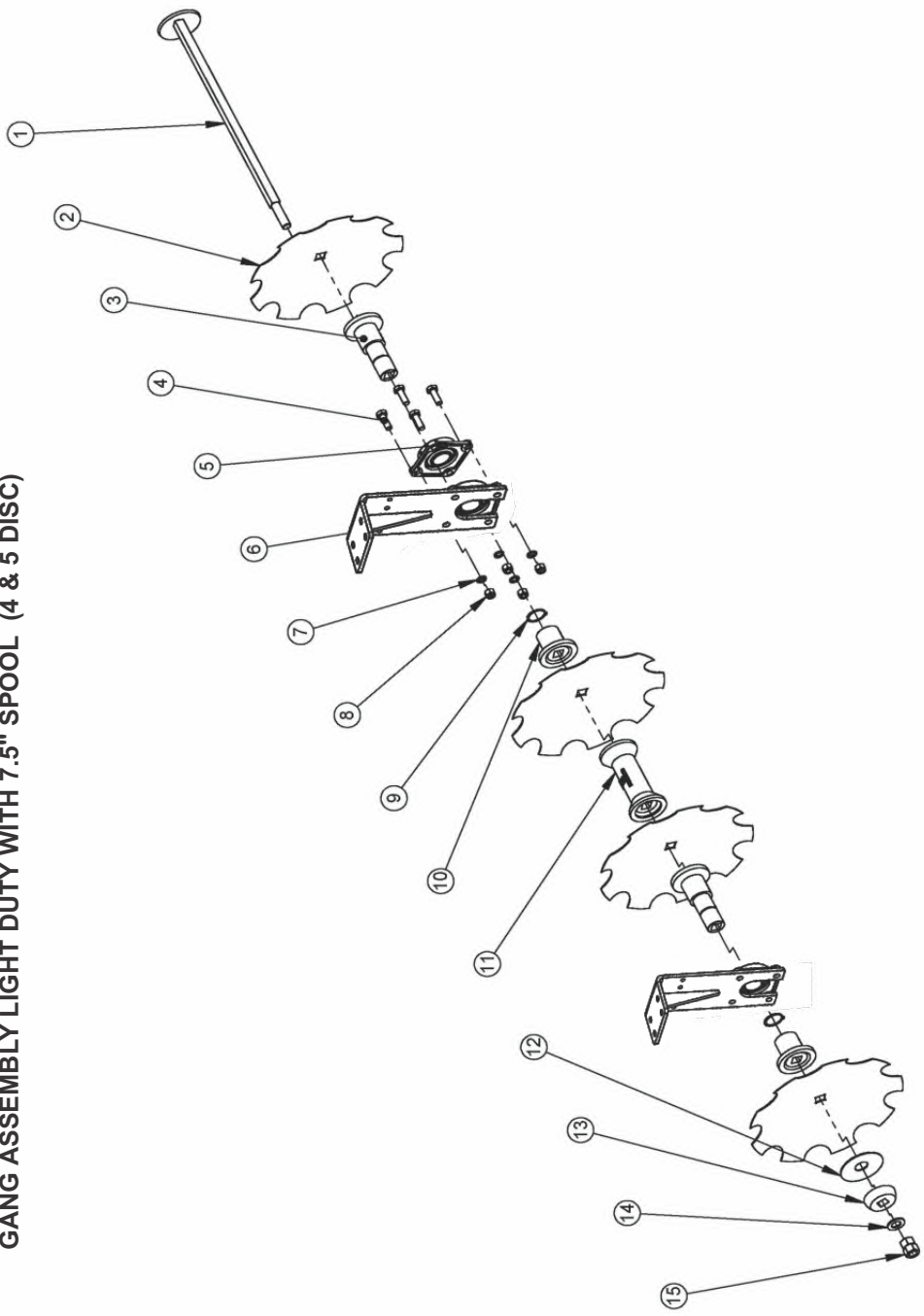

GANG ASSEMBLY LIGHT DUTY WITH 7.5" SPOOL (4 & 5 DISC)						
Sr. No.	DESCRIPTION	PART NO.		QTY.		
		4-DISC	5-DISC	4-DISC	5-DISC	
1	AXLE ROD ASSY.	77780008	77780009	1		
2	NOTCHED DISC 18"	10240032		4	5	
3	BEARING SPOOL (FOR 7.5" SPACING)	10340034		2		
4	HEX BOLT M16x50L (8.8)	10260358		8		
5	UC BEARING F210	10050031		2		
6	LEG . ASSY.	77800004		2		
7	SPRING WASHER 16MM	10270005		8		
8	NYLOCK NUT M16x2P	10280005		8		
9	EXTERNAL CIRCLIP 50A	10390010		2		
10	BEARING SPOOL CAP (FOR 7.5" SPACING)	10340035		2		
11	PLAIN SPOOL (7.5")	10340033		1	2	
12	DISC WASHER	10270029		1		
13	SMALL CHAPPEN	10360005		1		
14	PLAIN WASHER 25MM	10270024		1		
15	HEX NUT M24x3P	10280044		2		



## DELIVERY CHECKLIST

<b>Dealer Pre-Delivery (Please Tick)</b>	<b>Please Complete all Dealer information Below</b>
<p><b>1. Dealer Pre-Delivery Checklist</b></p> <ol style="list-style-type: none"> <li>1. The customer or person responsible has been given the operator's manual.</li> <li>2. The customer undertakes to read the complete operator's manual and understands all aspects of the manual before operation of the machine.</li> <li>3. All safety, operational and maintenance information have been explained and demonstrated.</li> <li>4. All greasing and oil points, stickers, guarding and ID plate have been identified and physically pointed out.</li> <li>5. The customer agrees that it is his responsibility to read and carry out the safety, maintenance and operation as per this operator's manual.</li> </ol>	<p><b>Dealer Information</b></p> <p>Dealer's Name.....</p> <p>Address.....</p> <p>State..... Postcode.....</p> <p>Phone..... Fax.....</p> <p>Email.....</p> <p>Service Person.....</p> <p>I confirm that the pre-delivery service was performed on this machine.</p> <p>Signature.....</p> <p>Date.....</p> <p>Comments.....</p>
<b>Customer Delivery (Please Tick)</b>	<b>Please Complete all Customer Information Below</b>
<p><b>2. Customer Delivery Checklist</b></p> <ol style="list-style-type: none"> <li>1. The customer or person responsible has been given the operator's manual.</li> <li>2. The customer undertakes to read the complete operator's manual and understands all aspects of the manual before operation of the machine.</li> <li>3. All safety, operational and maintenance information have been explained and demonstrated.</li> <li>4. All greasing and oil points, stickers, guarding and ID plate have been identified and physically pointed out.</li> <li>5. The customer agrees that it is his responsibility to read and carry out the safety, maintenance and operation as per this operator's manual.</li> </ol>	<p><b>Customer Information</b></p> <p>Customer's Name.....</p> <p>Address.....</p> <p>State..... Postcode.....</p> <p>Phone..... Fax.....</p> <p>Email.....</p> <p>Delivery Person.....</p> <p>I confirm that all of the delivery checks were explained and performed.</p> <p>Signature.....</p> <p>Delivery Date.....</p> <p>Comments.....</p>

# FIELDKING

## WARRANTY CARD Customer Copy

CUSTOMER NAME Mr./ Mrs. :

ADDRESS :

MOBILE NO. :

Email :

NAME OF IMPLEMENT :

MODEL NO. :

YEAR OF Mfg. :

SERIAL NO. :

REGISTRATION NO. :

DATE OF PURCHASING :

NAME OF DEALER :

Customer's Signature

Dealer's Signature



**Beri Udyog Pvt. Ltd.**

**Corporate Office :** Plot No. 235-236 & 238-240, Sec-3, HSIIDC,  
Karnal- 132001 (Haryana), India

+91-184-2221571/ 72/ 73  
✉ marketing@fieldking.com, exports@fieldking.com, 🌐 www.fieldking.com

# FIELDKING

## WARRANTY CARD Company Copy

CUSTOMER NAME Mr./ Mrs :

ADDRESS :

MOBILE NO. :

Email :

NAME OF IMPLEMENT :

MODEL NO. :

YEAR OF Mfg. :

SERIAL NO. :

REGISTRATION NO. :

DATE OF PURCHASING :

NAME OF DEALER :

Customer's Signature

Dealer's Signature



**Beri Udyog Pvt. Ltd.**

**Corporate Office :** Plot No. 235-236 & 238-240, Sec-3, HSIIDC,  
Karnal- 132001 (Haryana), India

+91-184-2221571/ 72/ 73  
✉ marketing@fieldking.com, exports@fieldking.com, 🌐 www.fieldking.com

# FIELDKING

## WARRANTY CARD Dealer Copy

CUSTOMER NAME Mr./ Mrs :

ADDRESS :

MOBILE NO. :

Email :

NAME OF IMPLEMENT :

MODEL NO. :

YEAR OF Mfg. :

SERIAL NO. :

REGISTRATION NO. :

DATE OF PURCHASING :

NAME OF DEALER :

Customer's Signature

Dealer's Signature



**Beri Udyog Pvt. Ltd.**

**Corporate Office :** Plot No. 235-236 & 238-240, Sec-3, HSIIDC,  
Karnal- 132001 (Haryana), India

☎ +91-184-2221571/ 72/ 73  
✉ marketing@fieldking.com, exports@fieldking.com, 🌐 www.fieldking.com